

DOMUSLIFT®

Technical Specifications



designed and made in Milan



DOMUSLIFT®
DOMUSLIFT XL
DOMUSLIFT S
DOMUSLIFT XS

Pag. 4

Pag. 8

Pag. 14

Pag. 15

Oleodinamico

- Conforme alla Direttiva Macchine Europea 2006/42/CE
- Azionamento oleodinamico senza locale macchine
- Sospensione diretta telescopica oppure in taglia con funi
- Portata fino a 300 kg
- Fino a 7 fermate, 12 metri di corsa
- Fossa a partire da 100 mm, testata da 2350 mm
- Velocità 0,15 m/s
- Potenza nominale 1,1 kW
- Dimensioni armadio 600 x 280 x 1000/1160 mm

Modello XL

- Fossa min 120 mm
- Testata min 2500 mm
- Fino a 7 fermate, 17 metri di corsa
- Potenza nominale 2,2 kW
- Portata 400 kg
- Velocità 0,15 m/s (0,30 m/s max al di fuori della Comunità Europea)
- Pistone in 1 o 2 pezzi
- Dimensioni massime di cabina: 1200 x 1500 mm

Dimensioni armadio con centralina e quadro di manovra (Modello XL):

- 720 x 360 x h 1500 mm (chiuso), 720 x 1050 x h 1500 mm (aperto) per corsa fino a 13 m
- 950 x 400 x h 1850 mm (chiuso), 950 x 850 x h 1850 mm (aperto) per corsa oltre 13 m

Hydraulic

- *Complying with European 2006/42/EC Machinery Directive*
- *Machine roomless hydraulic drive*
- *Direct telescopic suspension or roping version*
- *Load up to 300 kg*
- *Stops: up to 7; Travel: 12 m*
- *Pit starting from 100 mm, headroom from 2350 mm*
- *Speed: 0.15 m/s*
- *Rated power: 1.1 kW*
- *Cabinet dimensions: 600 x 280 x 1000/1160 mm*

XL model

- *Pit: 120 mm min*
- *Headroom: 2500 mm min*
- *Stops: up to 7; travel: 17 m*
- *Rated power: 2.2 kW*
- *Load: 400 kg*
- *Speed: 0.15 m/s (0.30 m/s max outside the European Community)*
- *1 or 2-piece ram*
- *Maximum car dimensions: 1200 x 1500 mm*

Cabinet dimensions with power unit and controller (XL model):

- *720 x 360 x h 1500 mm (closed), 720 x 1050 x h 1500 mm (open) for travels up to 13 m*
- *950 x 400 x h 1850 mm (closed), 950 x 850 x h 1850 mm (open) for travels >13 m*

Hydraulique

- Suivant la Directive Machines Européenne 2006/42/CE
- Fonctionnement hydraulique sans salle machines
- Suspension directe télescopique ou en taille avec câbles
- Charge jusqu'à 300 kg
- Jusqu'à 7 arrêts, course 12 metres
- Cuvette à partir de 100 mm, en-tête de 2350 mm
- Vitesse 0,15 m/s
- Puissance nominale 1,1 kW
- Dimensions armoire 600 x 280 x 1000/1160 mm

Modèle XL

- Cuvette min 120 mm
- En-tête min 2500 mm
- Jusqu'à 7 arrêts, course 17 metres
- Puissance nominale 2,2 kW
- Charge: 400 kg
- Vitesse 0,15 m/s (0,30 m/s max hors de la Communauté Européenne)
- Piston en 1 ou 2 pièces
- Dimensions maximales de cabine: 1200 x 1500 mm

Dimensions armoire avec centrale et tableau de commande (Modèle XL):

- 720 x 360 x h 1500 mm (fermé), 720 x 1050 x h 1500 mm (ouvert) pour course jusqu'à 13 m
- 950 x 400 x h 1850 mm (fermé), 950 x 850 x h 1850 mm (ouvert) pour course >13 m



DOMUSLIFT®

Pag. 16

Elettrico gearless con contrappeso

- Conforme alla Direttiva Macchine Europea 2006/42/CE
- MRL senza locale macchine
- Macchina gearless senza riduttore, con contrappeso (Potenza nominale 0,5 kW)
- Portata fino a 400 kg
- 7 fermate, 20 metri di corsa
- Fossa 200 mm, testata 2500/2600 mm
- Velocità 0,15 m/s (0,30 m/s max al di fuori della Comunità Europea)
- Dimensioni armadio 600 x 280 x 1160 mm

Electric gearless with counterweight

- *Complying with European 2006/42/EC Machinery Directive*
- *Machine roomless (MRL)*
- *Gearless machine, with counterweight (Rated power: 0.5 kW)*
- *Load up to 400 kg*
- *Stops: 7; Travel: 20 m*
- *Pit: 200 mm; Headroom: 2500/2600 mm*
- *Speed: 0.15 m/s (0.30 m/s max outside the European Community)*
- *Cabinet dimensions: 600 x 280 x 1160 mm*

Electrique gearless avec contrepoids

- Suivant la Directive Machines Européenne 2006/42/CE
- MRL sans salle machines
- Machine gearless avec contrepoids (Puissance nominale 0,5 kW)
- Charge jusqu'à 400 kg
- 7 arrêts, 20 metres de course
- Cuvette 200 mm, en-tête 2500/2600 mm
- Vitesse 0,15 m/s (0,30 m/s max hors de la Communauté Européenne)
- Dimensions armoire 600 x 280 x 1160 mm

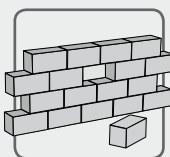

Vano in muratura - Misure nette tra i piombi con pareti finite

Masonry shaft - Net dimensions between finished walls

Gaine en maçonnerie - Dimensions nettes entre parois finies

Gemauerter Schacht - Lichte Breite zwischen den Schachtwänden

Hueco de obra - Medidas libres entre las paredes

Шахта в строительном исполнении - Чистые размеры между отделанными стенками

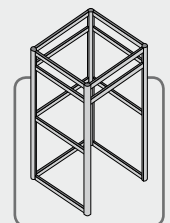

Incastellatura metallica - Fissaggio di almeno 3 montanti a livello fossa, testata e a ogni piano

Metal shaft structure - Fixing of at least 3 uprights at pit, headroom and each floor level

Structure métallique - Fixation d'au moins 3 montants au niveau de la cuvette, de la hauteur libre et à chaque étage

Metalschacht - Befestigung von mindestens 3 Pfosten auf Höhe der Grube, des Schachtkopfes und in jeder Etage

Estructura autoportante metálica - Fijaciones de por lo menos 3 puntos al nivel del foso, huida y uno mas en cada planta

Металлокаркасная шахта - Крепление по крайней мере 3 стойки на уровне прямка, оголовка и на каждом этаже

Hydraulisch

- Gemäß Europäischer Maschinenrichtlinie 2006/42/EG
- Ölhydraulischer Antrieb ohne Maschinenraum
- Direkt Teleskop oder Rucksack mit Seilen
- Tragfähigkeit bis 300 kg
- Bis zu 7 Haltestellen, 12 Meter Förderhöhe
- Schachtgrube ab 100 mm, Schachtkopf ab 2350 mm
- Geschwindigkeit 0,15 m/s
- Nennleistung 1,1 kW
- Schaltschrank 600 x 280 x 1000/1160 mm

Modell XL

- Schachtgrube min. 120 mm
- Schachtkopf min. 2500 mm
- Bis zu 7 Haltestellen, 17 m. Förderhöhe
- Nennleistung 2,2 kW
- Traglast: 400 kg
- Geschwindigkeit 0,15 m/s (0,30 m/s max auser Europäischer Gemeinschaft)
- Ein- oder zweiteiliger Zylinder
- Maximale Kabinenabmessungen: 1200 x 1500 mm

Schaltschrankabmessungen mit Antriebs- und Steuereinheit (Modell XL):

- 720 x 360 x h 1500 mm (geschlossen), 720 x 1050 x h 1500 mm (offen) für Förderhöhen bis 13 m
- 950 x 400 x h 1850 mm (geschlossen), 950 x 850 x h 1850 mm (offen) für Förderhöhen >13 m

Hidraulico

- Directiva Europea de Máquinas 2006/42/CE
- Tracción hidráulica sin cuarto de máquinas
- Suspensión directa telescópica o 2:1 con cables
- Carga hasta 300 kg
- Hasta 7 paradas, 12 metros de recorrido
- Foso a partir de 100 mm, huida de 2350 mm
- Velocidad 0,15 m/s
- Potencia nominal 1,1 kW
- Medidas armario 600 x 280 x 1000/1160 mm

Modelo XL

- Foso min 120 mm
- Huida min 2500 mm
- Hasta 7 paradas, 17 metros de recorrido
- Potencia nominal 2,2 kW
- Carga 400 kg
- Velocidad 0,15 m/s (0,30 m/s max fuera de la Comunidad Europea)
- Piston en 1 o 2 piezas
- Medidas máximas de cabina: 1200x1500 mm

Medidas armario con centralita y cuadro de maniobra (Modelo XL):

- 720 x 360 x h 1500 mm (cerrado), 720 x 1050 x h 1500 mm (abierto) por recorrido hasta 13 m
- 950 x 400 x h 1850 mm (cerrado), 950 x 850 x h 1850 mm (abierto) por recorrido >13 m

Гидравлический

- Соответствует Европейской Директиве 2006/42/ЕС «Машины и механизмы»
- Гидравлический привод без машинного помещения
- Прямая телескопическая подвеска или непрямая с канатами
- Грузоподъемность макс. 300 кг
- Макс. 7 остановок, высота подъема 12 метров
- Прямо́к мин. 100 мм, оголовок мин. 2350 мм
- Скорость 0,15 м/с
- Номинальная мощность 1,1 кВт
- Размеры шкафа 600 x 280 x 1000/1160 мм

Модель XL

- Прямо́к мин. 120 мм
- Оголовок мин. 2500 мм
- Макс. 7 остановок, высота подъема 17 метров
- Номинальная мощность 2,2 кВт
- Грузоподъемность 400 кг
- Скорость 0,15 м/с (0,30 м/с макс. за пределами Европейского Сообщества)
- Поршень 1 или 2 штуки
- Размеры кабины макс. 1200 x 1500 мм

Размеры шкафа с гидроприводом и щитом управления (Модель XL):

- 720 x 360 x в 1500 мм (закрытый), 720 x 1050 x в 1500 мм (открытый) для высоты подъема до 13 м
- 950 x 400 x в 1850 мм (закрытый), 950 x 850 x в 1850 мм (открытый) для высоты подъема >13 м

Elektrisch Getriebelos mit Gegengewicht

- Gemäß Europäischer Maschinenrichtlinie 2006/42/EG
- MRL (ohne Maschinenraum)
- Getriebelose Maschine (ohne Untersetzungsgetriebe) mit Gegengewicht (Nennleistung 0,5 kW)
- Tragfähigkeit bis 400 kg
- 7 Haltestellen, 20 Meter Förderhöhe
- Schachtgrube 200 mm, Schachtkopf 2500/2600 mm
- Geschwindigkeit 0,15 m/s (0,30 m/s max auser Europäischer Gemeinschaft)
- Schaltschrank 600 x 280 x 1160 mm

Electrico gearless con contrapeso

- Directiva Europea de Máquinas 2006/42/CE
- MRL sin cuarto de máquinas
- Máquina gearless sin reductor, con contrapeso (Potencia nominal 0,5 kW)
- Carga hasta 400 kg
- 7 paradas, 20 metros de recorrido
- Foso 200 mm, huida 2500/2600 mm
- Velocidad 0,15 m/s (0,30 m/s max fuera de la Comunidad Europea)
- Medidas armario 600 x 280 x 1160 mm

Электрический безредукторный с противовесом

- Соответствует Европейской Директиве 2006/42/ЕС «Машины и механизмы»
- БМП без машинного помещения
- Безредукторная машина, с противовесом (Номинальная мощность 0,5 кВт)
- Грузоподъемность макс. 400 кг
- 7 остановок, высота подъема 20 метров
- Прямо́к 200 мм, оголовок 2500/2600 мм
- Скорость 0,15 м/с (0,30 м/с макс. за пределами Европейского Сообщества)
- Размеры шкафа 600 x 280 x 1160 мм

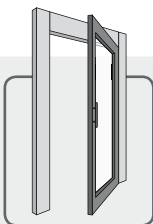

Porte a battente
Swing doors
Portes à battant
Drehtüren
Puerta manual
Распашные двери

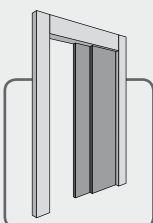

Porte automatique scorrevoli
Automatic sliding doors
Portes automatiques coulissantes
Automatische Schiebetüren
Puertas automáticas deslizantes
Автоматические раздвижные двери

CW - CD Cabina / Car / Cabine
Kabine / Cabina / Кабина

SW - SD Vano / Shaft / Gaine
Schacht / Hueco / Шахта

DO Porta / Door / Porte
Tür / Puerta / Дверь

kg Portata / Load / Charge / Tragkraft
Carga util / Грузоподъемность

 Capienza / Capacity / Capacité
Tragfähigkeit / Cabida / Вместительность

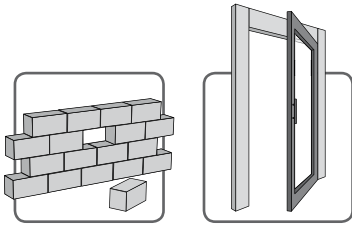

Oleodinamico
Hydraulic
Hydraulique
Hydraulisch
Hidraulico
Гидравлический

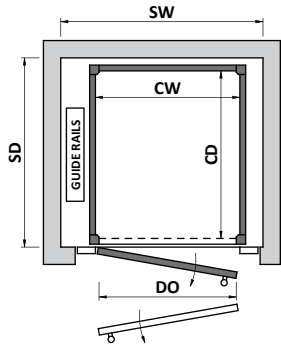

1C	1C/1	1C/2	1C/3	1C/4	1C/5	1C/6	1C/7	1C/8	1C/12
CW	830	830	830	1030	1030	1030	830	1130	1030
CD	830	1030	1300	1300	1030	830	1200	1400	1400
SW	1160	1160	1160	1360	1360	1360	1160	1460	1360
SD	950	1150	1450	1450	1150	950	1350	1550	1550
DO	750	750	750	950	950	950	750	900	950
kg max	300	300	340	400	340	340	300	400	400
♿ max	3	4	5	6	4	4	3	4	5

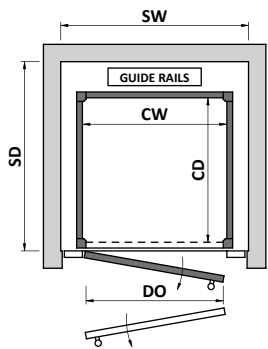

1L	1L/1	1L/2	1L/3	1L/4	1L/5	1L/6	1L/7
CW	830	1030	1300	1300	1030	830	830
CD	830	830	830	1030	1030	1030	1200
SW	1030	1230	1530	1530	1230	1030	1030
SD	1106	1106	1106	1306	1306	1306	1476
DO	750	950	950	950	950	750	750
kg max	300	300	340	400	340	340	400
♿ max	3	4	5	6	4	4	3

Disponibili cabine con dimensioni intermedie.
Cars with intermediate dimensions are available.
Cabines avec dimensions intermoyennes sont disponibles.
Zwischenmasse der Kabinen sind verfügbare.
Cabinas disponibles con dimensiones medianas.
В наличии кабины с промежуточными размерами.

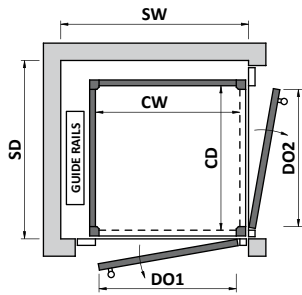

2A	2A/1	2A/2	2A/3	2A/4	2A/5	2A/6	2A/7	2A/9
CW	830	830	830	1030	1030	1030	1200	1200
CD	830	1030	1300	1300	1030	830	830	1200
SW	1106	1106	1106	1306	1306	1306	1476	1476
SD	975	1175	1445	1445	1175	975	975	1345
DO1	750	750	750	950	950	950	950	950
DO2	750	950	950	950	950	750	750	950
kg max	300	300	340	400	340	340	400	400
♿ max	3	4	5	6	4	4	5	3

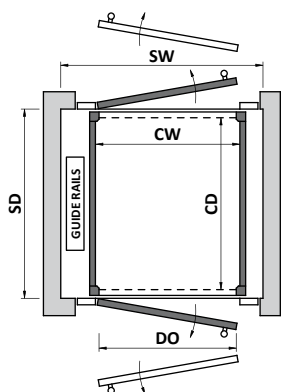

2P	2P/1	2P/2	2P/3	2P/4	2P/5	2P/6	2P/7	2P/8
CW	830	830	830	1030	1030	1030	830	1130
CD	830	1030	1300	1300	1030	830	1200	1400
SW	1160	1160	1160	1360	1360	1360	1160	1460
SD	920	1120	1390	1390	1120	920	1290	1490
DO	750	750	750	950	950	950	750	900
kg max	300	300	340	400	340	340	300	400
♿ max	3	4	5	6	4	4	3	5

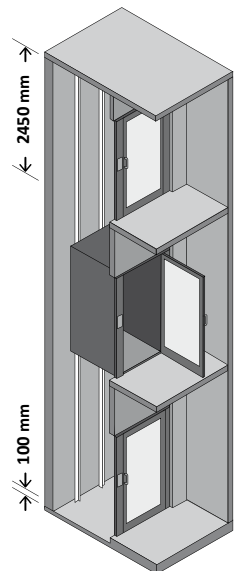

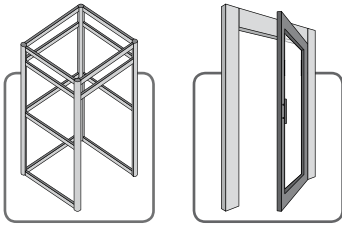

Oleodinamico
Hydraulic
Hydraulique
Hydraulisch
Hidraulico
Гидравлический

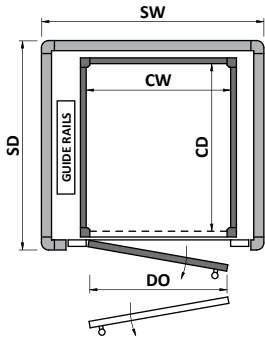

1C	1C/1	1C/2	1C/3	1C/4	1C/5	1C/6	1C/7	1C/8	1C/12
CW	830	830	830	1030	1030	1030	830	1130	1030
CD	830	1030	1300	1300	1030	830	1200	1400	1400
SW	1330	1330	1330	1530	1530	1530	1330	1630	1530
SD	1070	1270	1570	1570	1270	1070	1470	1660	1660
DO	750	750	750	950	950	950	750	900	950
kg max	300	300	340	400	340	340	300	400	400
♿ max	3	4	5	6	4	4	3	4	5

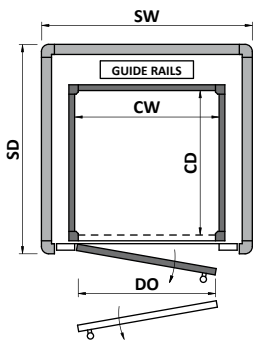

1L	1L/1	1L/2	1L/3	1L/4	1L/5	1L/6	1L/7
CW	830	1030	1300	1300	1030	830	830
CD	830	830	830	1030	1030	1030	1200
SW	1250	1450	1700	1700	1450	1250	1195
SD	1221	1221	1221	1421	1421	1421	1621
DO	750	950	950	950	950	750	750
kg max	300	300	340	400	340	340	400
♿ max	3	4	5	6	4	4	3

Disponibili cabine con dimensioni intermedie.
Cars with intermediate dimensions are available.
Cabines avec dimensions intermoyennes sont disponibles.
Zwischenmasse der Kabinen sind verfügbare.
Cabinas disponibles con dimensiones medianas.
В наличии кабины с промежуточными размерами.

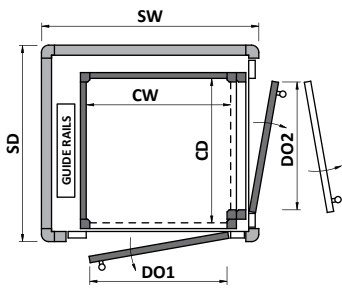

2A	2A/1	2A/2	2A/3	2A/4	2A/5	2A/6	2A/7	2A/9
CW	830	830	830	1030	1030	1030	1200	1200
CD	830	1030	1300	1300	1030	830	830	1200
SW	1286	1286	1286	1486	1486	1486	1656	1656
SD	1145	1345	1615	1615	1345	1145	1145	1515
DO1	750	750	750	950	950	950	950	950
DO2	685	750	950	950	750	685	685	950
kg max	300	300	340	400	340	300	400	400
♿ max	3	4	5	6	4	3	4	5

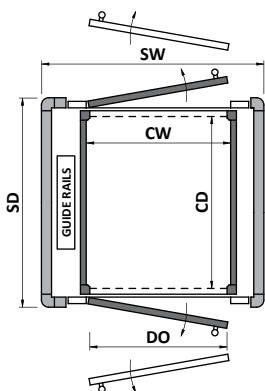

2P	2P/1	2P/2	2P/3	2P/4	2P/5	2P/6	2P/7	2P/8
CW	830	830	830	1030	1030	1030	830	1130
CD	830	1030	1300	1300	1030	830	1200	1400
SW	1330	1330	1330	1540	1545	1530	1330	1630
SD	1040	1240	1510	1510	1240	1040	1410	1610
DO	750	750	750	950	950	950	750	900
kg max	300	300	340	400	340	340	300	400
♿ max	3	4	5	6	4	4	3	5

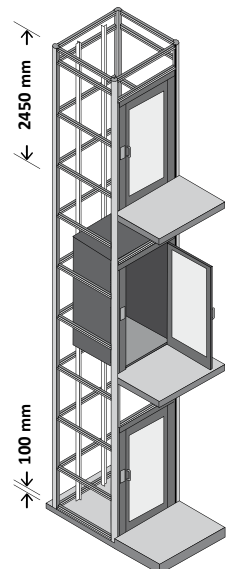

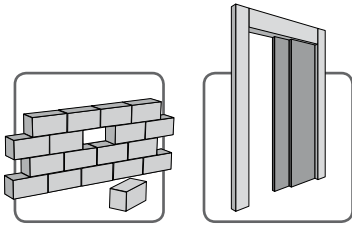

Oleodinamico
Hydraulic
Hydraulique
Hydraulisch
Hidraulico
Гидравлический

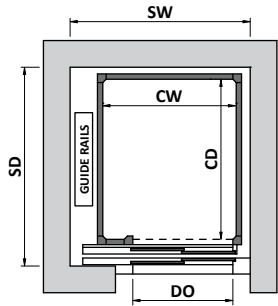

1C-2AT	1C/2	1C/3	1C/4	1C/5	1C/7	1C/10
CW	830	830	1030	1030	830	980
CD	1030	1300	1300	1030	1200	1200
SW	1160	1160	1350	1350	1160	1310
SD	1290	1590	1590	1290	1490	1490
DO	650	650	750	750	650	750
kg max	300	340	400	340	300	400
♿ max	👤👤👤	👤👤👤	♿👤👤👤👤	👤👤👤	👤👤👤	♿👤👤👤

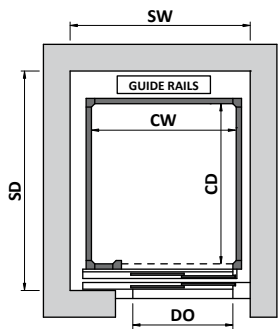

1L-2AT	1L/2	1L/3	1L/5
CW	1030	1300	1030
CD	830	830	1030
SW	1460	1460	1460
SD	1240	1240	1440
DO	850	850	850
kg max	300	340	340
♿ max	👤👤👤	👤👤👤	👤👤👤

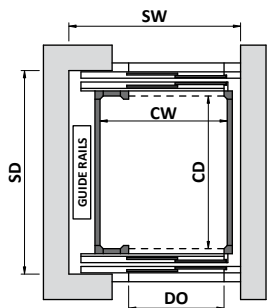

2P-2AT	2P/2	2P/3	2P/4	2P/5	2P/7
CW	830	830	1030	1030	830
CD	1030	1300	1300	1030	1200
SW	1160	1160	1350	1350	1170
SD	1382	1652	1652	1382	1552
DO	650	650	750	750	650
kg max	300	340	400	340	300
♿ max	👤👤👤	👤👤👤	♿👤👤👤👤	👤👤👤	👤👤👤

Disponibili cabine con dimensioni intermedie.
Cars with intermediate dimensions are available.
Cabines avec dimensions intermoyennes sont disponibles.
Zwischenmasse der Kabinen sind verfügbare.
Cabinas disponibles con dimensiones medianas.
В наличии кабины с промежуточными размерами.

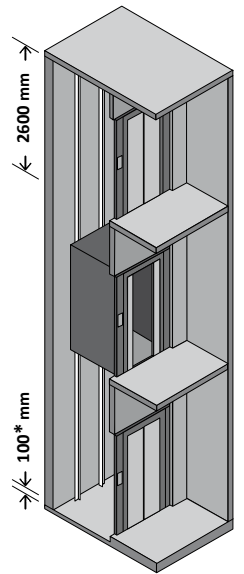

*150 mm
на Русской Федерации,
Белоруссии и Казахстане

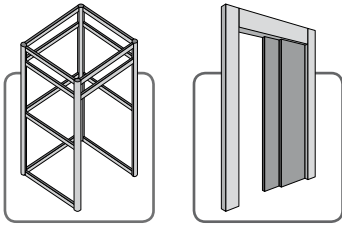

Oleodinamico
Hydraulic
Hydraulique
Hydraulisch
Hidraulico
Гидравлический

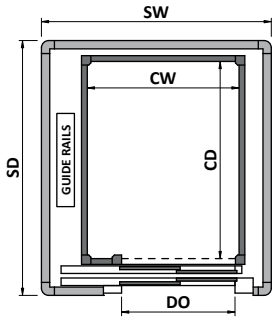

1C-2AT	1C/2	1C/3	1C/4	1C/5	1C/7	1C/10
CW	830	830	1030	1030	830	980
CD	1030	1300	1300	1030	1200	1200
SW	1340	1340	1520	1520	1340	1490
SD	1385	1685	1685	1385	1585	1585
DO	650	650	750	750	650	750
kg max	300	340	400	340	300	400
♿ max	👤👤👤	👤👤👤	♿👤👤👤👤	👤👤👤	👤👤👤	♿👤👤👤

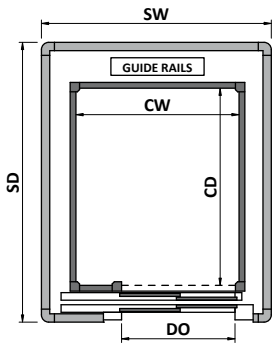

1L-2AT	1L/2	1L/3	1L/5
CW	1030	1300	1030
CD	830	830	1030
SW	1640	1640	1640
SD	1340	1340	1540
DO	850	850	850
kg max	300	340	340
♿ max	👤👤👤	👤👤👤	👤👤👤

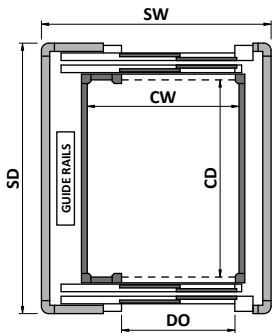

2P-2AT	2P/2	2P/3	2P/4	2P/5	2P/7
CW	830	830	1030	1030	830
CD	1030	1300	1300	1030	1200
SW	1340	1340	1520	1520	1340
SD	1472	1742	1742	1472	1642
DO	650	650	750	750	650
kg max	300	340	400	340	300
♿ max	👤👤👤	👤👤👤	♿👤👤👤👤	👤👤👤	👤👤👤

Disponibili cabine con dimensioni intermedie.
Cars with intermediate dimensions are available.
Cabines avec dimensions intermoyennes sont disponibles.
Zwischenmasse der Kabinen sind verfügbare.
Cabinas disponibles con dimensiones medianas.
В наличии кабины с промежуточными размерами.

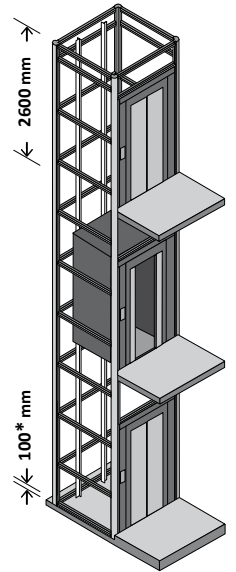

*150 mm
на Русской Федерации,
Белоруссии и Казахстане

DOMUSLIFT® XL

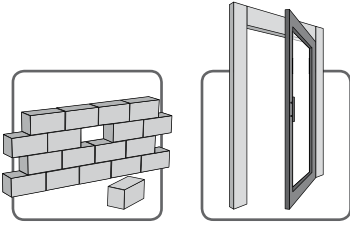

Oleodinamico
Hydraulic
Hydraulique
Hydraulisch
Hidraulico
Гидравлический

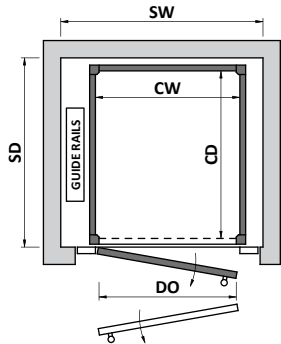

1C	
CW	1130
CD	1400
SW	1460
SD	1520
DO	900
kg max	450
♿ max	♿ 👤 👤 👤 👤 👤

	min	max
CW	630	1200
CD	830	1500
SW	960	1530
SD	935	1650
DO	550	950
kg	250	450
♿	♿ 👤	♿ 👤 👤 👤 👤

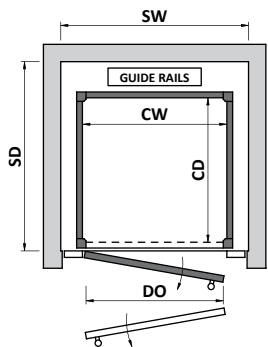

1L	
CW	830
CD	1200
SW	1030
SD	1480
DO	750
kg max	400
♿ max	♿ 👤 👤 👤 👤

	min	max
CW	680	1500
CD	630	1200
SW	900	1670
SD	910	1480
DO	600	950
kg	250	450
♿	♿ 👤	♿ 👤 👤 👤 👤

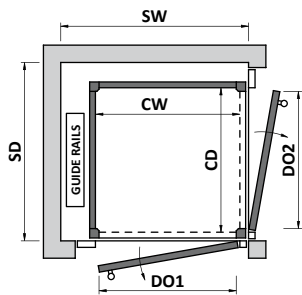

2A	
CW	1200
CD	1200
SW	1480
SD	1345
DO1	950
DO2	950
kg max	400
♿ max	♿ 👤 👤 👤 👤

	min	max
CW	630	1200
CD	950	1500
SW	910	1480
SD	1095	1645
DO1	550	950
DO2	750	950
kg	250	450
♿	♿ 👤	♿ 👤 👤 👤 👤

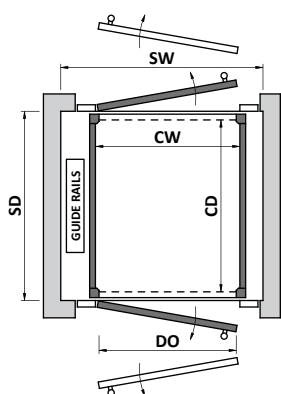

2P	
CW	1130
CD	1400
SW	1460
SD	1490
DO	900
kg max	450
♿ max	♿ 👤 👤 👤 👤

	min	max
CW	630	1200
CD	830	1500
SW	960	1530
SD	920	1590
DO	550	950
kg	250	450
♿	♿ 👤	♿ 👤 👤 👤 👤

Versioni consigliate. Disponibili cabine con altre dimensioni.

Suggested versions. Cars with other dimensions are also available.

Versions conseillées. Cabines avec autres dimensions sont disponibles.

Empfohlene Ausführungen. Kabinen mit verschiedenen Massen sind verfügbare.

Versiones aconsejadas. Cabinas disponibles con dimensiones distintas.

Варианты рекомендованные. В наличии кабины с разными размерами.

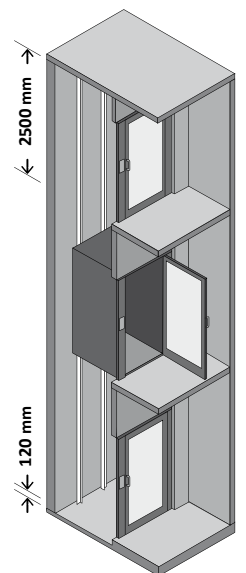

DOMUSLIFT® XL

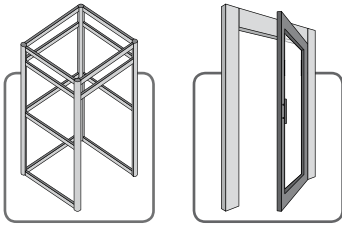

Oleodinamico
Hydraulic
Hydraulique
Hydraulisch
Hidraulico
Гидравлический

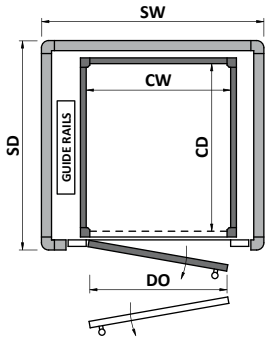

1C	
CW	1130
CD	1400
SW	1630
SD	1630
DO	900
kg max	450
♿ max	♿ ██████

	min	max
CW	630	1200
CD	1020	1500
SW	1130	1700
SD	1250	1730
DO	550	950
kg	250	450
♿	████	♿ ██████

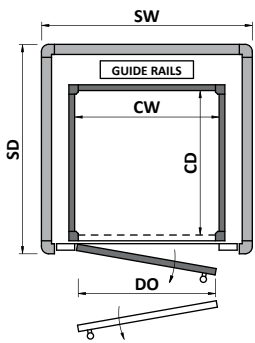

1L	
CW	830
CD	1200
SW	1250
SD	1595
DO	750
kg max	400
♿ max	♿ ██████

	min	max
CW	830	1400
CD	630	1200
SW	1230	1735
SD	1025	1595
DO	750	950
kg	250	450
♿	████	♿ ██████

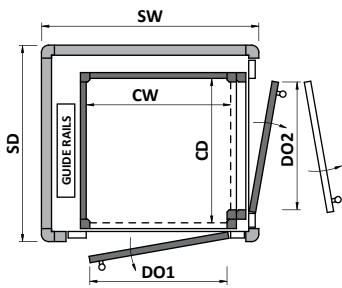

2A	
CW	1200
CD	1200
SW	1660
SD	1515
DO1	950
DO2	950
kg max	400
♿ max	♿ ██████

	min	max
CW	630	1200
CD	1000	1400
SW	1090	1660
SD	1315	1715
DO1	550	950
DO2	750	950
kg	250	450
♿	████	♿ ██████

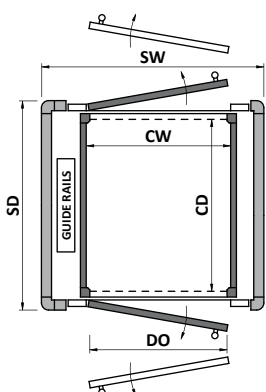

2P	
CW	1130
CD	1400
SW	1630
SD	1610
DO	900
kg max	450
♿ max	♿ ██████

	min	max
CW	630	1200
CD	1030	1500
SW	1130	1700
SD	1240	1710
DO	550	950
kg	250	450
♿	████	♿ ██████

Versioni consigliate.
Disponibili cabine
con altre dimensioni.

*Suggested versions. Cars
with other dimensions
are also available.*

Versions conseillées.
Cabines avec autres
dimensions sont
disponibles.

*Empfohlene
Ausführungen. Kabinen
mit verschiedenen
Massen sind verfügbar.*

Versiones aconsejadas.
Cabinas disponibles con
dimensiones distintas.

*Варианты
рекомендованные.
В наличии кабины с
разными размерами.*

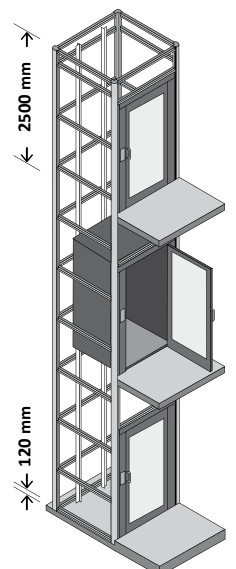

DOMUSLIFT® XL

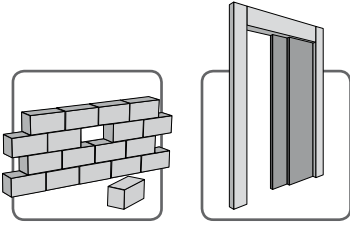

Oleodinamico
Hydraulic
Hydraulique
Hydraulisch
Hidraulico
Гидравлический

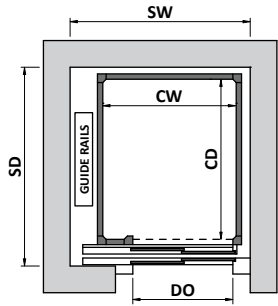

1C-2AT							
CW	830	830	980	1030	1030	1130	1130
CD*	1030	1300	1200	1030	1300	1400	1400
SW	1160	1160	1310	1350	1350	1450	1535
SD	1270	1550	1450	1270	1550	1650	1650
DO	650	650	750	750	750	800	900
kg max	400	400	400	400	400	450	450
♿ max	4	4	4	4	4	4	4

* CD min = 930

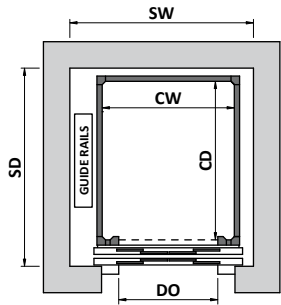

1C-4AO			
CW	880	1130	1130
CD*	1200	1400	1400
SW	1350	1500	1550
SD	1450	1650	1650
DO	800	850	950
kg max	400	450	450
♿ max	4	4	4

* CD min = 930

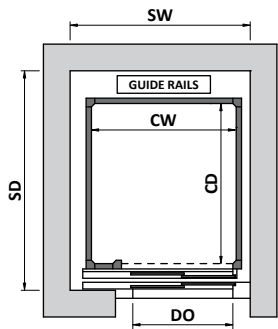

1L-2AT				
CW*	930	1030	1300	1500
CD	830	1200	1200	1200
SW	1160	1310	1535	1700
SD	1241	1611	1611	1611
DO	650	750	900	950
kg max	400	400	450	450
♿ max	3	4	4	4

* CW min = 780

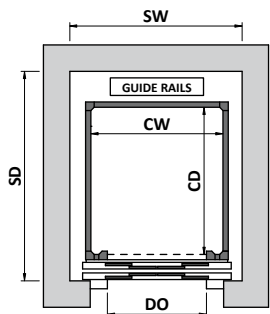

1L-4AO			
CW	830	1030	1200
CD*	1200	1200	1200
SW	1250	1250	1400
SD	1611	1611	1611
DO	750	750	850
kg max	400	400	400
♿ max	4	4	4

* CW min = 780

Versioni consigliate. Disponibili cabine con altre dimensioni.

Suggested versions. Cars with other dimensions are also available.

Versions conseillées. Cabines avec autres dimensions sont disponibles.

Empfohlene Ausführungen. Kabinen mit verschiedenen Massen sind verfügbar.

Versiones aconsejadas. Cabinas disponibles con dimensiones distintas.

Варианты рекомендованные. В наличии кабины с разными размерами.

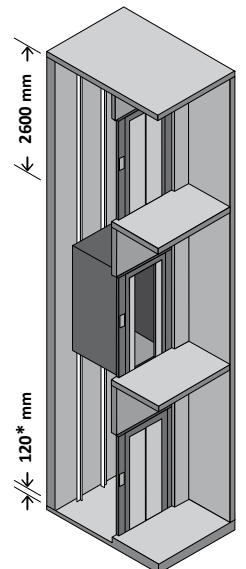

* 170 мм (200 мм при скорости 0,30 м/с) на Русской Федерации, Белоруссии и Казахстане

DOMUSLIFT® XL

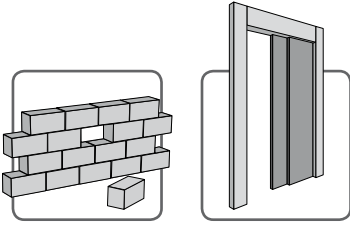

Oleodinamico
Hydraulic
Hydraulique
Hydraulisch
Hidraulico
Гидравлический

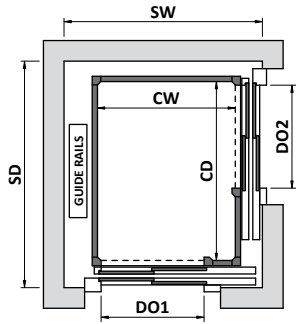

2A-2AT			
CW	1030	1030	1130
CD*	1200	1300	1400
SW	1441	1441	1541
SD	1466	1566	1666
DO1	750	750	800
DO2	700	750	800
kg max	400	400	450
♿ max	♿♿♿♿	♿♿♿♿	♿♿♿♿

* CD min = 930

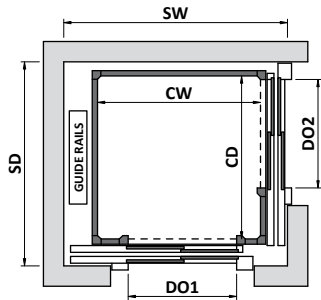

2A-2AT	
CW	1200
CD	1200
SW	1611
SD	1466
DO1	800
DO2	800
kg max	400
♿ max	♿♿♿♿

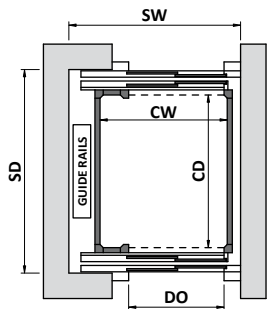

2P-2AT						
CW	830	830	980	1030	1030	1130
CD*	1030	1300	1200	1030	1300	1400
SW	1160	1160	1310	1350	1350	1450
SD	1382	1652	1552	1382	1652	1752
DO	650	650	750	750	750	800
kg max	400	400	400	400	400	450
♿ max	♿♿♿	♿♿♿♿	♿♿♿♿♿	♿♿♿♿	♿♿♿♿♿	♿♿♿♿♿

* CD min = 920

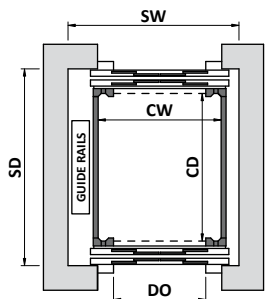

2P-4AO			
CW	880	1130	1130
CD*	1200	1400	1400
SW	1350	1500	1600
SD	1552	1752	1752
DO	800	850	950
kg max	400	450	450
♿ max	♿♿♿♿	♿♿♿♿♿	♿♿♿♿♿

* CD min = 980

Versioni consigliate. Disponibili cabine con altre dimensioni.

Suggested versions. Cars with other dimensions are also available.

Versions conseillées. Cabines avec autres dimensions sont disponibles.

Empfohlene Ausführungen. Kabinen mit verschiedenen Massen sind verfügbare.

Versiones aconsejadas. Cabinas disponibles con dimensiones distintas.

Варианты рекомендованные. В наличии кабины с разными размерами.

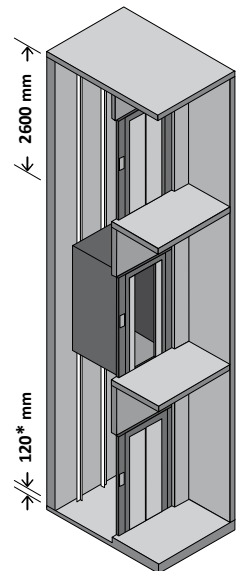

* 170 мм (200 мм при скорости 0,30 м/с) на Русской Федерации, Белоруссии и Казахстане

DOMUSLIFT® XL

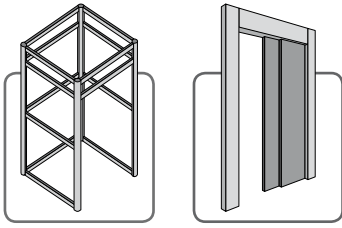

Oleodinamico
Hydraulic
Hydraulique
Hydraulisch
Hidraulico
Гидравлический

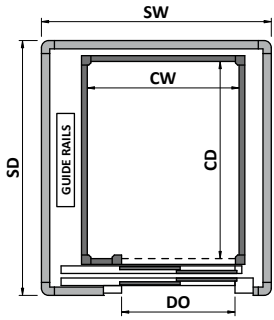

1C-2AT					
CW	830	830	980	1030	1030
CD*	1030	1300	1200	1030	1300
SW	1350	1350	1500	1530	1530
SD	1380	1650	1550	1380	1650
DO	650	650	750	750	750
kg max	400	400	400	400	400
♿ max	👤👤👤	👤👤👤	♿👤👤👤	👤👤👤	♿👤👤👤

* CD min = 930

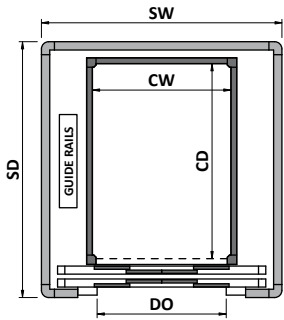

1C-4AO	
CW	880
CD*	1200
SW	1495
SD	1550
DO	800
kg max	400
♿ max	♿👤👤👤

* CD min = 930

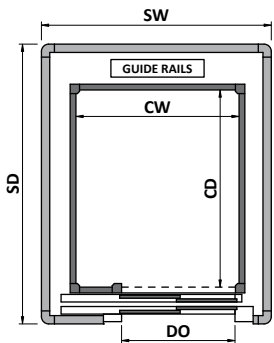

1L-2AT			
CW*	930	1030	1300
CD	830	1200	1200
SW	1350	1500	1730
SD	1341	1711	1711
DO	650	750	900
kg max	400	400	450
♿ max	👤👤	♿👤👤	♿👤👤

* CW min = 780

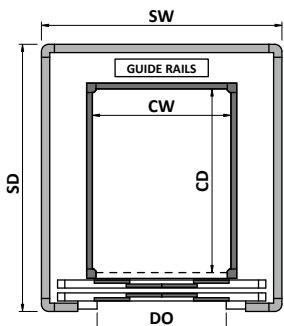

1L-4AO		
CW*	1030	1200
CD	1200	1200
SW	1400	1550
SD	1711	1711
DO	750	850
kg max	400	400
♿ max	♿👤👤	♿👤👤

* CW min = 780

Versioni consigliate.
Disponibili cabine
con altre dimensioni.

*Suggested versions. Cars
with other dimensions
are also available.*

Versions conseillées.
Cabines avec autres
dimensions sont
disponibles.

*Empfohlene
Ausführungen. Kabinen
mit verschiedenen
Massen sind verfügbar.*

Versiones aconsejadas.
Cabinas disponibles con
dimensiones distintas.

*Варианты
рекомендованные.
В наличии кабины с
разными размерами.*

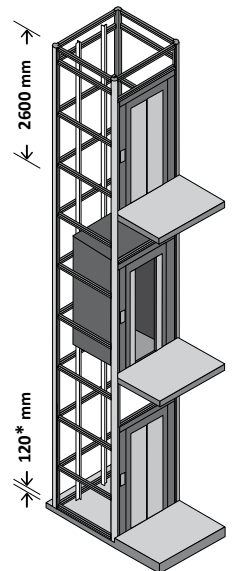

* 170 мм (200 мм при
скорости 0,30 м/с)
на Русской Федерации,
Белоруссии и Казахстане

DOMUSLIFT® XL

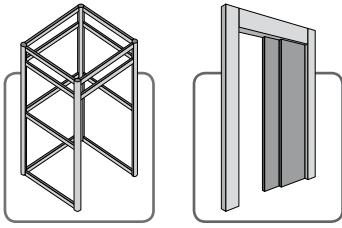

Oleodinamico
Hydraulic
Hydraulique
Hydraulisch
Hidraulico
Гидравлический

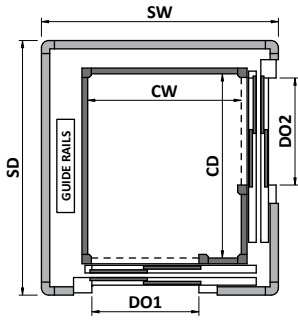

2A-2AT		
CW	1030	1030
CD*	1200	1300
SW	1541	1541
SD	1630	1730
DO1	700	700
DO2	700	750
kg max	400	400
♿ max	♿♿♿♿	♿♿♿♿

* CD min = 930

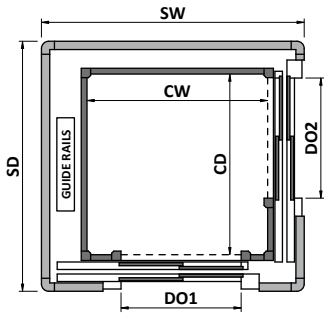

2A-2AT	
CW	1200
CD	1200
SW	1721
SD	1630
DO1	800
DO2	800
kg max	400
♿ max	♿♿♿♿

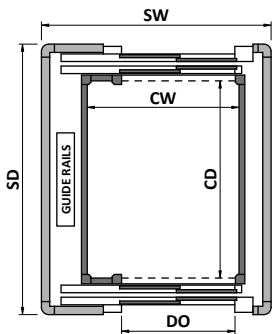

2P-2AT					
CW	830	830	980	1030	1030
CD*	1030	1300	1200	1030	1300
SW	1350	1350	1500	1530	1530
SD	1472	1742	1642	1472	1742
DO	650	650	750	750	750
kg max	400	400	400	400	400
♿ max	♿♿♿	♿♿♿♿	♿♿♿♿♿	♿♿♿♿	♿♿♿♿♿

* CD min = 980

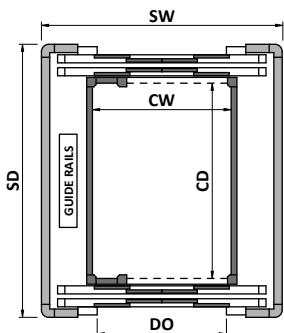

2P-4AO	
CW	880
CD*	1200
SW	1500
SD	1642
DO	800
kg max	400
♿ max	♿♿♿♿

* CD min = 930

Versioni consigliate.
Disponibili cabine
con altre dimensioni.

*Suggested versions. Cars
with other dimensions
are also available.*

Versions conseillées.
Cabines avec autres
dimensions sont
disponibles.

*Empfohlene
Ausführungen. Kabinen
mit verschiedenen
Massen sind verfügbbar.*

Versiones aconsejadas.
Cabinas disponibles con
dimensiones distintas.

*Варианты
рекомендованные.
В наличии кабины с
разными размерами.*

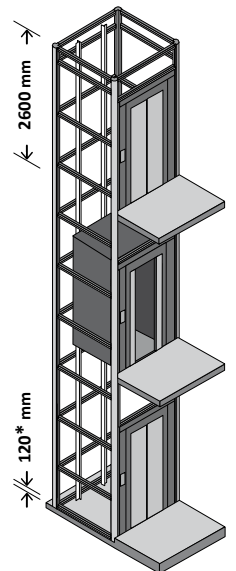

* 170 мм (200 мм при
скорости 0,30 м/с)
на Русской Федерации,
Белоруссии и Казахстане

DOMUSLIFT® S - SMALL

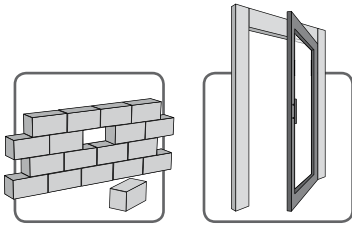

Oleodinamico
Hydraulic
Hydraulique
Hydraulisch
Hidraulico
Гидравлический

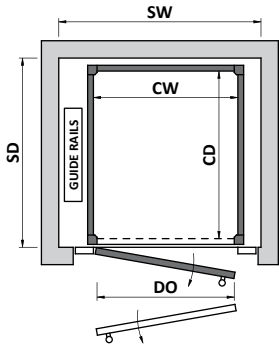

1C	1C/S1	1C/S2
CW	800	550
CD	800	690
SW	1150	900
SD	890	780
DO	800	550
kg max	250	250
♿ max	👤👤👤	👤

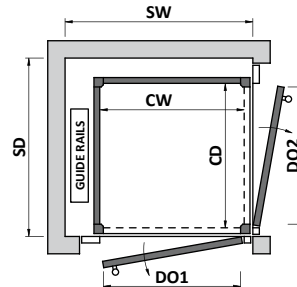

2A	2A/S1	2A/S2
CW	795	595
CD	795	620
SW	1070	870
SD	955	780
DO1	735	535
DO2	735	560
kg max	250	250
♿ max	👤👤👤	👤

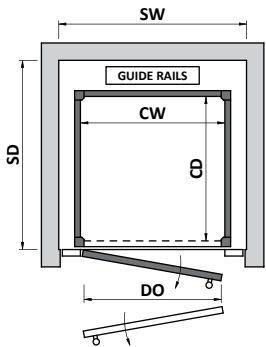

1L	1L/S1	1L/S2
CW	800	580
CD	800	550
SW	1005	785
SD	1070	820
DO	800	580
kg max	250	250
♿ max	👤👤👤	👤

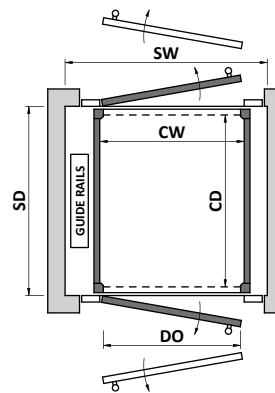

2P	2P/S1	2P/S2
CW	800	550
CD	800	700
SW	1150	900
SD	880	780
DO	800	550
kg max	250	250
♿ max	👤👤👤	👤

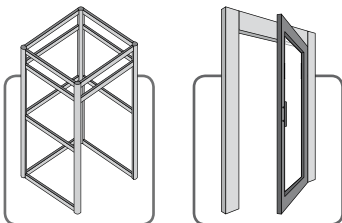

Oleodinamico
Hydraulic
Hydraulique
Hydraulisch
Hidraulico
Гидравлический

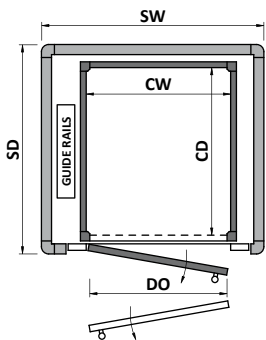

1C	1C/S1	1C/S2
CW	800	550
CD	800	760
SW	1280	1030
SD	1020	980
DO	800	550
kg max	250	250
♿ max	👤👤👤	👤

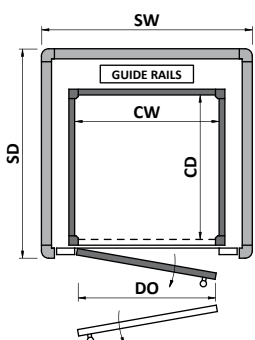

1L	1L/S1	1L/S2
CW	800	550
CD	800	550
SW	1225	975
SD	1185	935
DO	800	550
kg max	250	250
♿ max	👤👤👤	👤

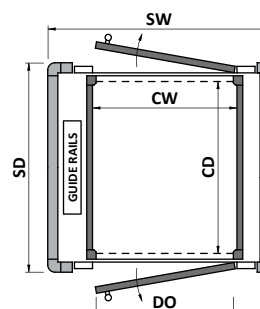

2P	2P/S1	2P/S2
CW	800	550
CD	800	780
SW	1280	1030
SD	1000	980
DO	800	550
kg max	250	250
♿ max	👤👤👤	👤

Disponibili cabine con dimensioni intermedie.
Cars with intermediate dimensions are available.
Cabines avec dimensions intermoyennes sont disponibles.
Zwischenmasse der Kabinen sind verfuegbar.
Cabinas disponibles con dimensiones medianas.
В наличии кабины с промежуточными размерами.

DOMUSLIFT® XS - EXTRA SMALL

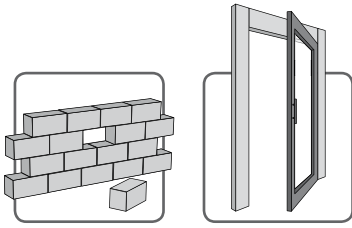

Oleodinamico
Hydraulic
Hydraulique
Hydraulisch
Hidraulico
Гидравлический

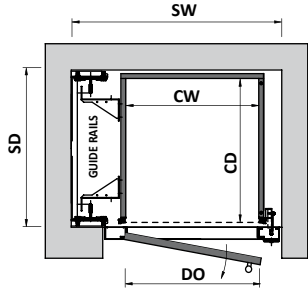

1C	min
CW	550
CD	580
SW	870
SD	670
DO	550
kg	250

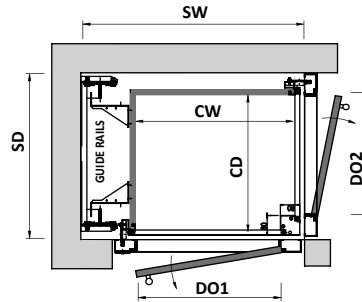

2A	min
CW	660
CD	580
SW	930
SD	715
DO1	600
DO2	520
kg	250

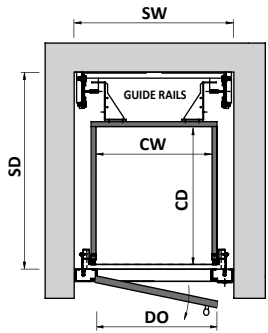

1L	min
CW	480
CD	550
SW	670
SD	820
DO	480
kg	250

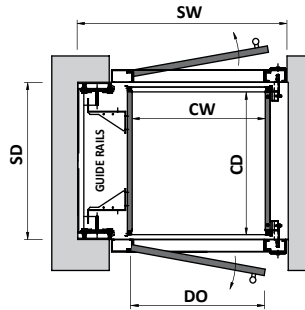

2P	min
CW	550
CD	580
SW	870
SD	660
DO	550
kg	250

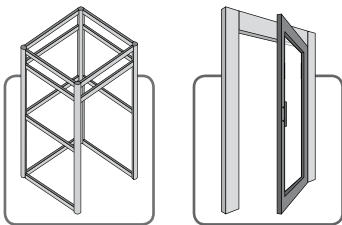

Oleodinamico
Hydraulic
Hydraulique
Hydraulisch
Hidraulico
Гидравлический

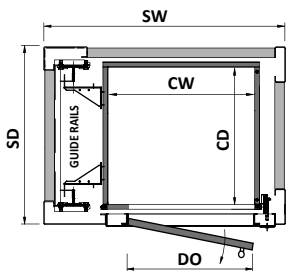

1C	min
CW	565
CD	490
SW	965
SD	660
DO	480
kg	250

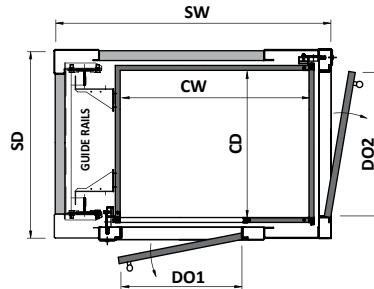

2A	min
CW	750
CD	600
SW	1110
SD	770
DO1	480
DO2	600
kg	250

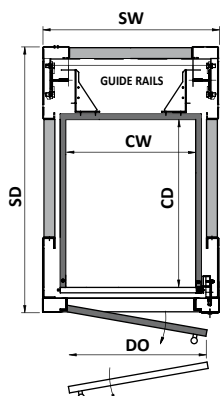

1L	min
CW	480
CD	550
SW	650
SD	910
DO	480
kg	250

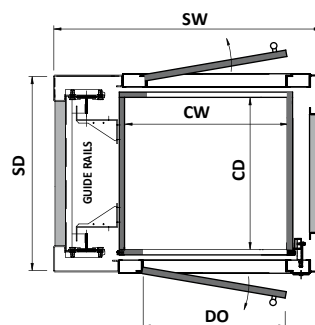

2P	min
CW	565
CD	490
SW	965
SD	660
DO	480
kg	250

DOMUSLIFT® GEARLESS

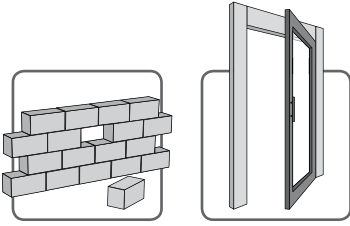

Elettrico gearless con contrappeso
Electric gearless with counterweight
Electrique gearless avec contrepoids
Elektrisch Getriebelos mit Gegengewicht
Electrico gearless con contrapeso
Электрический безредукторный с противовесом

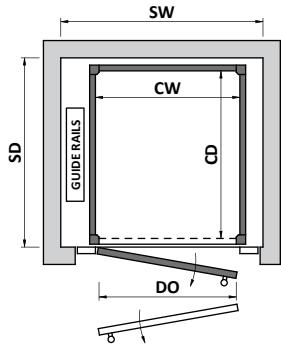

1C	1C/3	1C/4	1C/7	1C/8
CW	830	1030	830	1130
CD*	1300	1300	1200	1400
SW	1320	1520	1320	1620
SD	1410	1410	1310	1510
DO	750	950	750	900
kg max	300	400	300	450
♿ max	♿	♿	♿	♿

* CD min = 1130

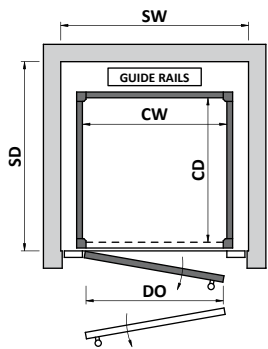

1L	1L/2	1L/3	1L/4	1L/5
CW*	1030	1300	1300	1030
CD	830	830	1030	1030
SW	1230	1500	1500	1230
SD	1265	1265	1465	1465
DO	950	950	950	950
kg max	300	340	400	340
♿ max	♿	♿	♿	♿

* CW min = 1030

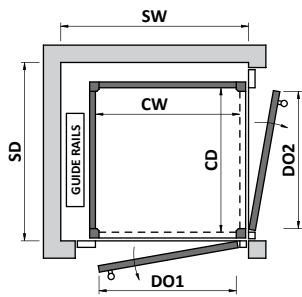

2A	2A/3	2A/4
CW	830	1030
CD*	1300	1300
SW	1265	1465
SD	1445	1445
DO1	750	950
DO2	950	950
kg max	340	400
♿ max	♿	♿

* CD min = 1130

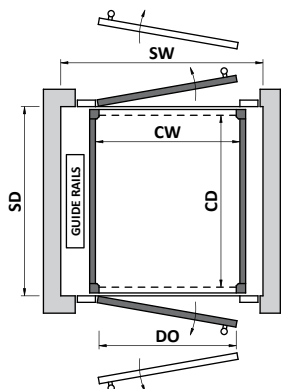

2P	2P/3	2P/4	2P/7	2P/8
CW	830	1030	830	1130
CD*	1300	1300	1200	1400
SW	1320	1520	1320	1620
SD	1390	1390	1290	1490
DO	750	950	750	900
kg max	340	400	300	450
♿ max	♿	♿	♿	♿

* CD min = 1230

Disponibili cabine con dimensioni intermedie.
Cars with intermediate dimensions are available.
 Cabines avec dimensions intermoyennes sont disponibles.
Zwischenmasse der Kabinen sind verfuegbar.
 Cabinas disponibles con dimensiones medianas.
В наличии кабины с промежуточными размерами.

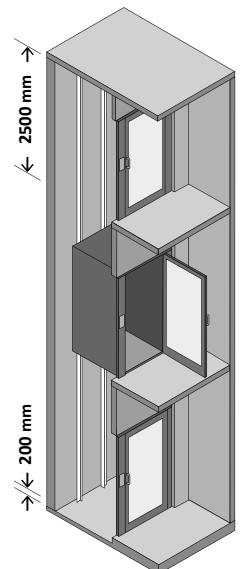

DOMUSLIFT® GEARLESS

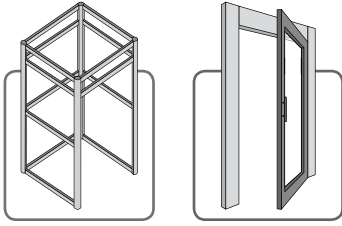

Elettrico gearless con contrappeso
Electric gearless with counterweight
Electrique gearless avec contrepoids
Elektrisch Getriebelos mit Gegengewicht
Electrico gearless con contrapeso
Электрический безредукторный с противовесом

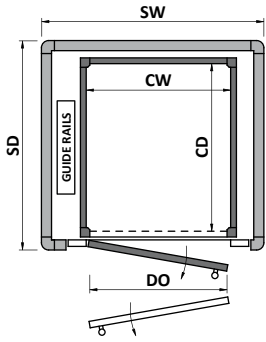

1C	1C/3	1C/4	1C/7	1C/8
CW	830	1030	830	1130
CD*	1300	1300	1200	1400
SW	1490	1690	1490	1790
SD	1550	1550	1450	1650
DO	750	950	750	900
kg max	340	400	300	450
♿ max	♿	♿	♿	♿

* CD min = 1130

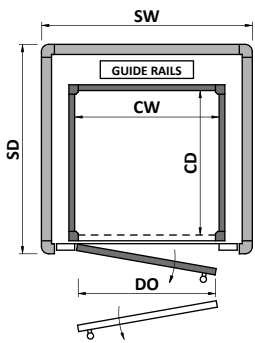

1L	1L/3	1L/4
CW*	1300	1300
CD	830	1030
SW	1650	1650
SD	1385	1585
DO	950	950
kg max	340	400
♿ max	♿	♿

* CW min = 1130

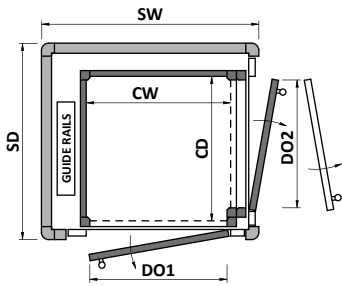

2A	2A/3	2A/4
CW	830	1030
CD*	1300	1300
SW	1450	1650
SD	1615	1615
DO1	750	950
DO2	950	950
kg max	340	400
♿ max	♿	♿

* CD min = 1130

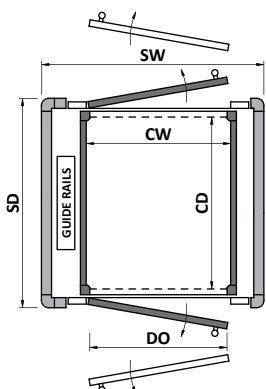

2P	2P/3	2P/4	2P/7	2P/8
CW	830	1030	830	1130
CD*	1300	1300	1200	1400
SW	1490	1690	1490	1790
SD	1510	1510	1410	1610
DO	750	950	750	900
kg max	340	400	300	450
♿ max	♿	♿	♿	♿

* CD min = 1230

Disponibili cabine con dimensioni intermedie.
 Cars with intermediate dimensions are available.
 Cabines avec dimensions intermoyennes sont disponibles.
 Zwischenmasse der Kabinen sind verfuegbar.
 Cabinas disponibles con dimensiones medianas.
 В наличии кабины с промежуточными размерами.

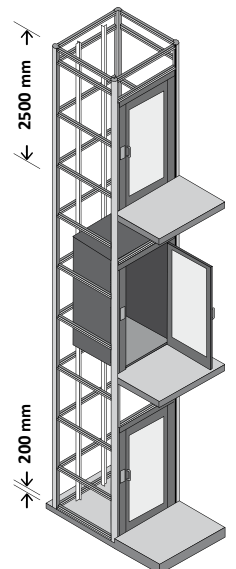

DOMUSLIFT® GEARLESS

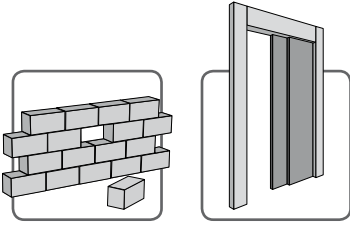

Elettrico gearless con contrappeso
Electric gearless with counterweight
Electrique gearless avec contrepoids
Elektrisch Getriebelos mit Gegengewicht
Electrico gearless con contrapeso
Электрический безредукторный с противовесом

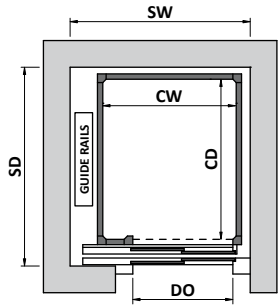

1C-2AT				
CW	830	980	1030	1130
CD*	1300	1200	1300	1400
SW	1310	1460	1510	1610
SD	1550	1450	1550	1650
DO	750	800	850	900
kg max	340	400	400	450
♿ max	♿	♿	♿	♿

* CD min = 1130

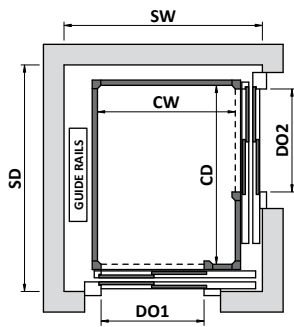

2A-2AT			
CW	1030	1030	1130
CD*	1200	1300	1400
SW	1596	1596	1696
SD	1466	1566	1666
DO1	750	750	850
DO2	800	850	850
kg max	400	400	450
♿ max	♿	♿	♿

* CD min = 1200

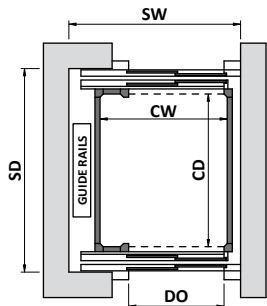

2P-2AT				
CW	830	980	1030	1130
CD*	1300	1200	1300	1400
SW	1310	1460	1510	1610
SD	1652	1552	1652	1752
DO	750	800	850	900
kg max	340	400	400	450
♿ max	♿	♿	♿	♿

* CD min = 1200

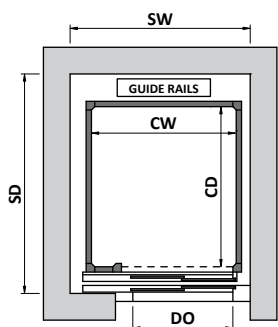

1L-2AT	
CW*	1300
CD	1130
SW	1535
SD	1696
DO	900
kg max	400
♿ max	♿

* CW min = 1130

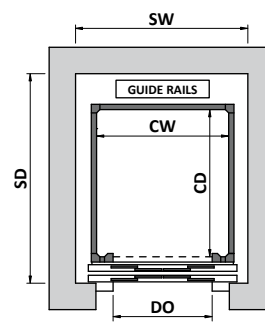

1L-4AO	
CW	1130
CD*	1130
SW	1350
SD	1696
DO	800
kg max	400
♿ max	♿

* CW min = 1130

Versioni consigliate.
Disponibili cabine con altre dimensioni.
Suggested versions. Cars with other dimensions are also available.
Versions conseillées.
Cabines avec autres dimensions sont disponibles.
Empfohlene Ausfuehrungen. Kabinen mit verschiedenen Massen sind verfuegbar.
Versiones aconsejadas.
Cabinas disponibles con dimensiones distintas.
Варианты рекомендованные. В наличии кабины с разными размерами.

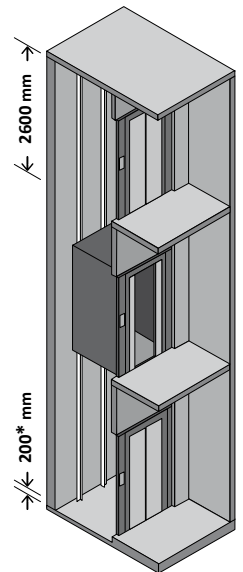

*250 мм на Русской Федерации, Белоруссии и Казахстане

DOMUSLIFT® GEARLESS

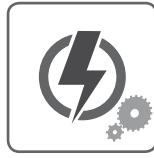
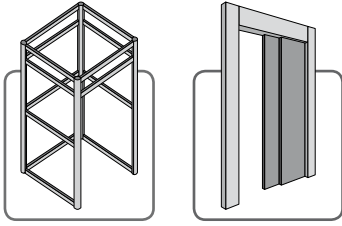

Elettrico gearless con contrappeso
Electric gearless with counterweight
Electrique gearless avec contrepoids
Elektrisch Getriebelos mit Gegengewicht
Electrico gearless con contrapeso
Электрический безредукторный с противовесом

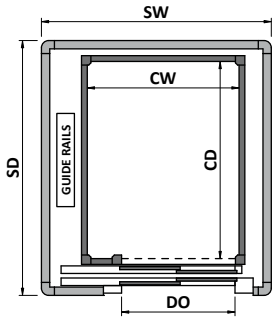

1C-2AT			
CW	830	980	1030
CD*	1300	1200	1300
SW	1500	1650	1690
SD	1650	1550	1650
DO	750	800	850
kg max	340	400	400
♿ max	♿	♿	♿

* CD min = 1130

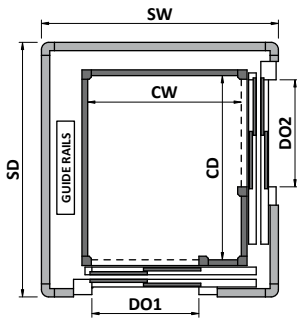

2A-2AT	
CW	1030
CD*	1200
SW	1701
SD	1630
DO1	750
DO2	750
kg max	400
♿ max	♿

* CD min = 1200

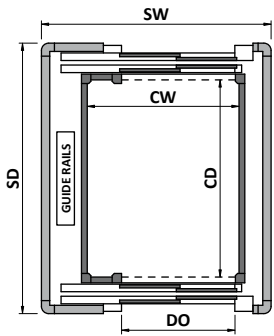

2P-2AT			
CW	830	980	1030
CD*	1300	1200	1300
SW	1500	1650	1690
SD	1742	1642	1742
DO	750	800	850
kg max	340	400	400
♿ max	♿	♿	♿

* CD min = 1200

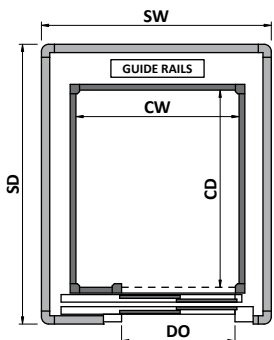

1L-2AT	
CW*	1300
CD	1130
SW	1720
SD	1801
DO	900
kg max	400
♿ max	♿

* CW min = 1130

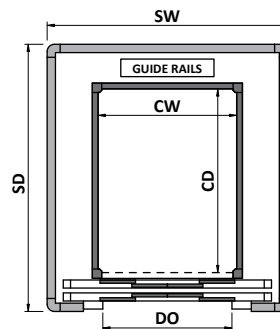

1L-4AO	
CW*	1130
CD	1130
SW	1490
SD	1801
DO	800
kg max	400
♿ max	♿

* CW min = 1130

Versioni consigliate. Disponibili cabine con altre dimensioni.

Suggested versions. Cars with other dimensions are also available.

Versions conseillées. Cabines avec autres dimensions sont disponibles.

Empfohlene Ausführungen. Kabinen mit verschiedenen Massen sind verfügbare.

Versiones aconsejadas. Cabinas disponibles con dimensiones distintas.

Варианты рекомендованные. В наличии кабины с разными размерами.

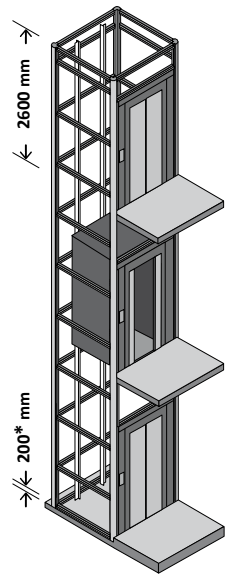

*250 мм на Русской Федерации, Белоруссии и Казахстане

Leading company in the production of customised products since 1966

Founded by Giuseppe Volpe in 1966, IGV Group is worldwide renown for the design and production of DomusLift lifting platforms and lifts with reduced pit and headroom. IGV exports to more than 70 Countries 85% of its total production, representing the excellence of Made in Italy. For more than 50 years, IGV has been designing and manufacturing thousands of solutions for the vertical mobility, specialising in bespoke systems and exporting worldwide the Made in Italy style and innovative technology.

Member of



Certified by



IGV Group SpA

Via Di Vittorio, 21
20060 Vignate, Milan - Italy
+39 02 95127 1

www.domuslift.com
www.igvlift.com